

SERVICE BULLETIN

SB No. 68 Issue No. 3

TITLE
CANOPY LATCH CORRECT OPERATION INSPECTION
CLASSIFICATION

Highly Recommended

COMPLIANCE

Within 50 Flying Hours

APPLICABILITY:

T67C, T67M and T67M200 Aircraft, Post Mod M129 (Split Canopy), T67M-MkII, T67M260 and T67M260-T3A.

INTRODUCTION:

An incident has occurred where the canopy latch was apparently closed correctly but when engine revs were increased beyond 1500 RPM the canopy opened.

Fig. 1 page 2 shows 3 positions of the canopy mechanism:

Position 1 - Open/Unlatched

Position 2 - Latched but mechanism not over centre

Position 3 - Correctly closed, mechanism fully over centre.

ACTION:

- (i) Remove canopy mechanism and latch covers
- (ii) Close canopy fully. Ensure internal handle is in its correct position and external handle is in its correct position, ie touching bush or no more than 1mm gap. Fig. 1.
- (iii) Check that stop pin is just touching latch hook or no more than 1mm from it. If not adjust in accordance with Maintenance Manual, Section 3, paragraphs 3.2.
- (iv) If (ii) and (iii) cannot be met after adjustment, then it is acceptable to slot latch block Ref. Fig. 3. Suitably re-protect cut surfaces and re-identify block as Part Number T67G-17-531 Post Mod M713B. Annotate Logbook accordingly.
- (v) Check closure. By positioning palm of hand at point indicated, ref. Fig. 1, push up latch handle, which should close with reasonable resistance but without using excessive force.

ISSUED 21 JUN 1996
ISSUED BY:

Date 20.6.96.

 for and on behalf of **SLINGSBY AVIATION LIMITED**
 Kirkbymoorside, York YO6 6EZ England Tel 0751 32474 Telex 57597

Page 1 of 5

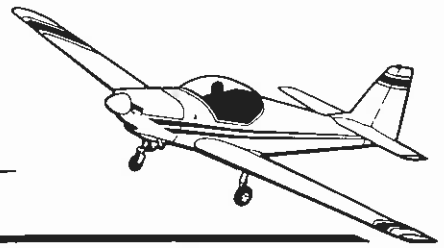
**SERVICE BULLETIN**

SB No.

68

Issue No.

3*

TITLE

CANOPY LATCH CORRECT OPERATION INSPECTION

CONTINUED

- (vi) Replace mechanism and latch covers, in accordance with Maintenance Manual, Section 3, paragraphs 3.2.
- (vii) Maintenance Manuals to be amended to reflect points contained in (ii), (iii), (iv) and (v).
- (viii) When handle is fully closed, ie meets requirements of Fig. 1, mark a white line across both labels ref. Fig. 2 on line with handle lower surface (ie coincident with Point 'A' ref Fig. 1 & 2. The line may be obtained by running a hacksaw across both labels; a) deep enough to reveal white of label material or b) if base material is red, deep enough to hold white fill in wax, ie 0.25mm to 0.5mm.

When label is marked, it is to be identified in IPC Ref. Chapter 15 as Part No. T67M-17-351 Post Mod M666, Part No. T67M-17-319 to be annotated Pre Mod M666. Annotate Logbook Mod M666 incorporated.

- (ix) Providing the mechanism is correctly adjusted it should be obvious to the pilot that the latch mechanism has gone overcentre.
- (x) On completion of this SB, annotate Logbook SB68 complied with.

If in doubt, contact SAL Product Support Department.

Approved:



Date:

20.6.96.

Page

2

of

5

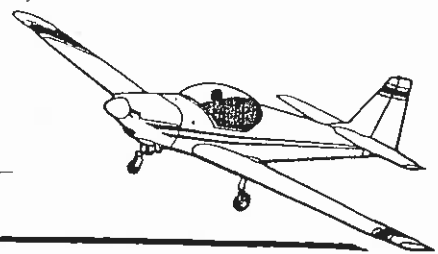

SERVICE BULLETIN

SB No. 68

Issue No. 3

TITLE

CANOPY LATCH CORRECT OPERATION INSPECTION

CONTINUED

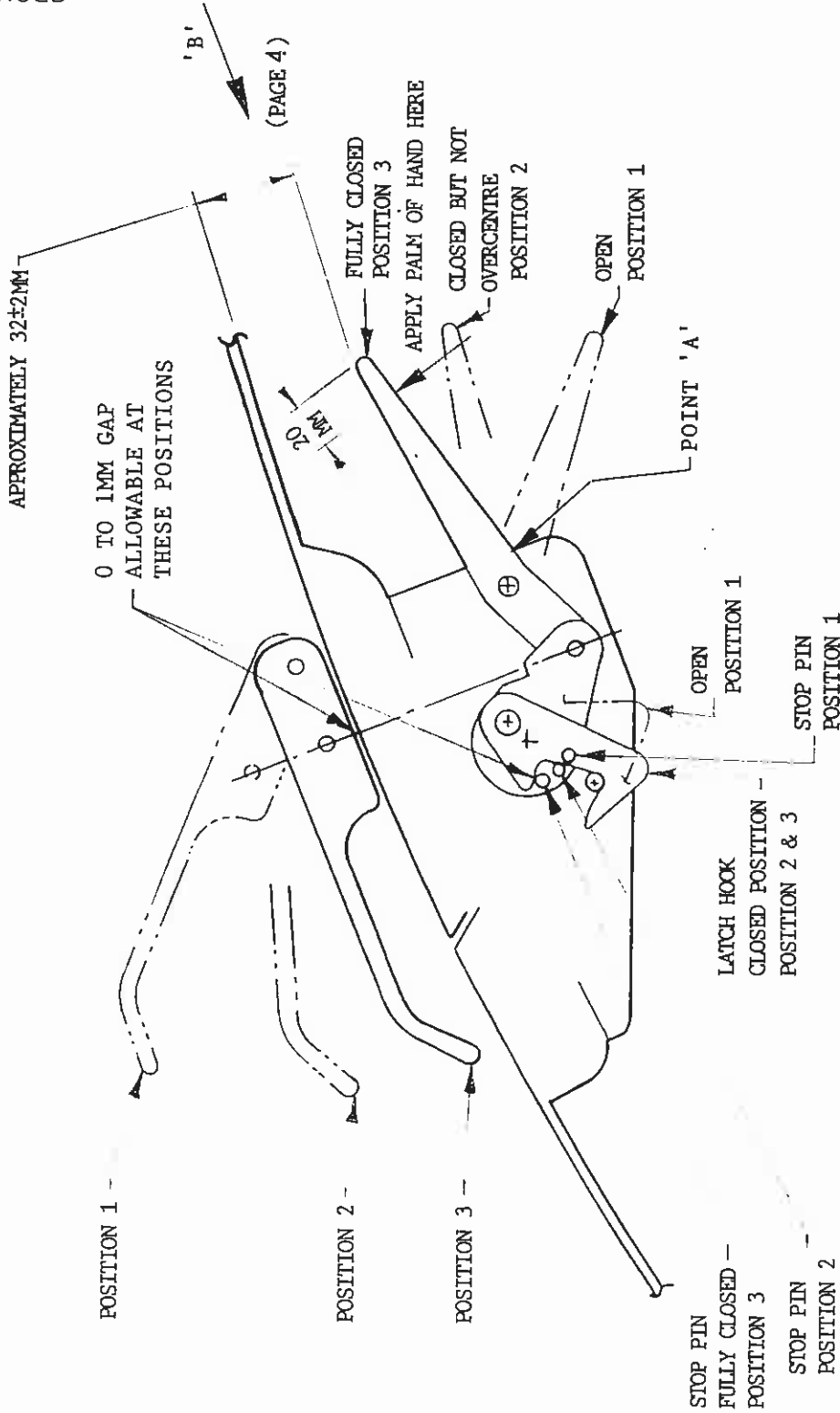

Fig 1

Approved:

[Signature]

Date:

20.6.96

Page

3

of

5

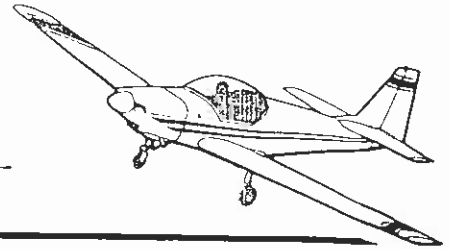

SERVICE BULLETIN

SB No. 68

68

Issue No. 3

3

TITLE

CANOPY LATCH CORRECT OPERATION INSPECTION

CONTINUED

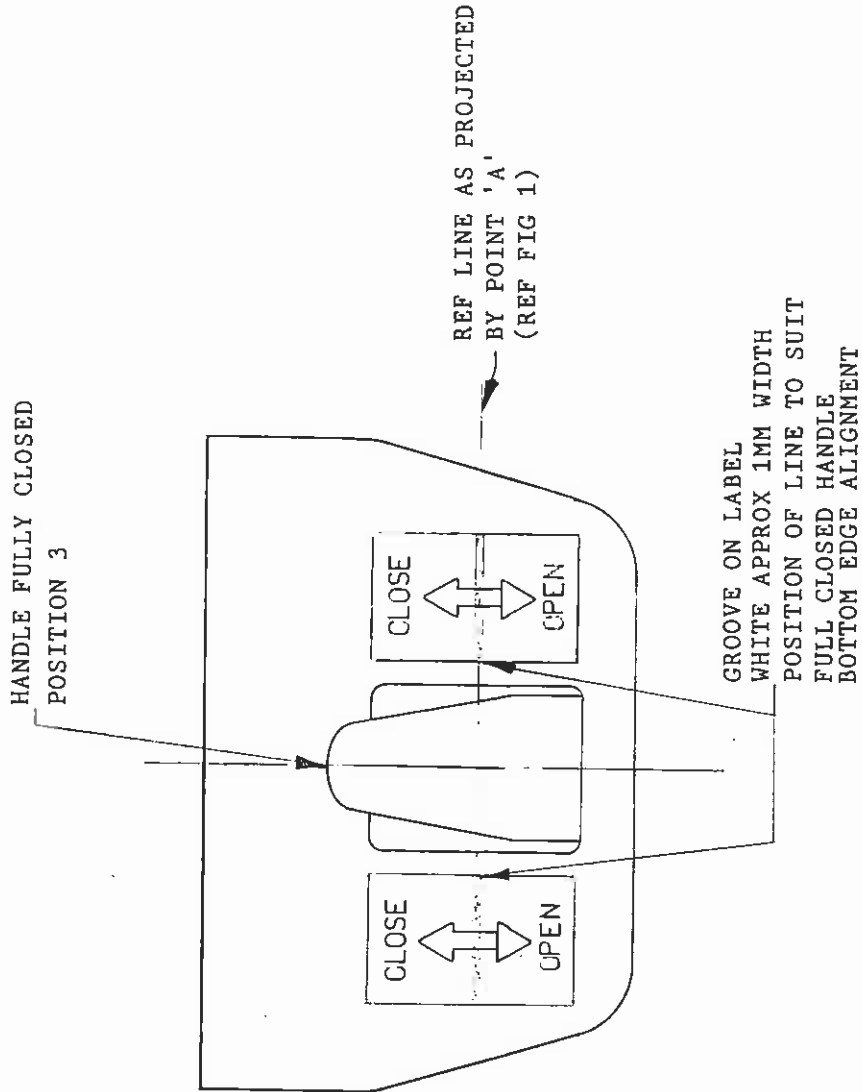

FIG 2
VIEW ON ARROW 'B' (REF FIG 1)

Approved:

[Handwritten signature]

Date:

20.6.96.

Page

4

of

5

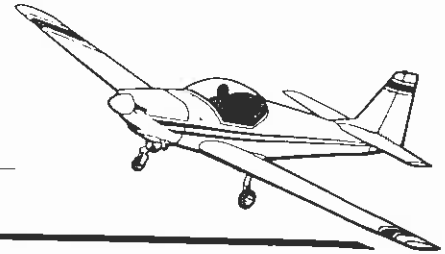

SERVICE BULLETIN

SB No. 68

Issue No. 3

TITLE

CANOPY LATCH CORRECT OPERATION INSPECTION

CONTINUED

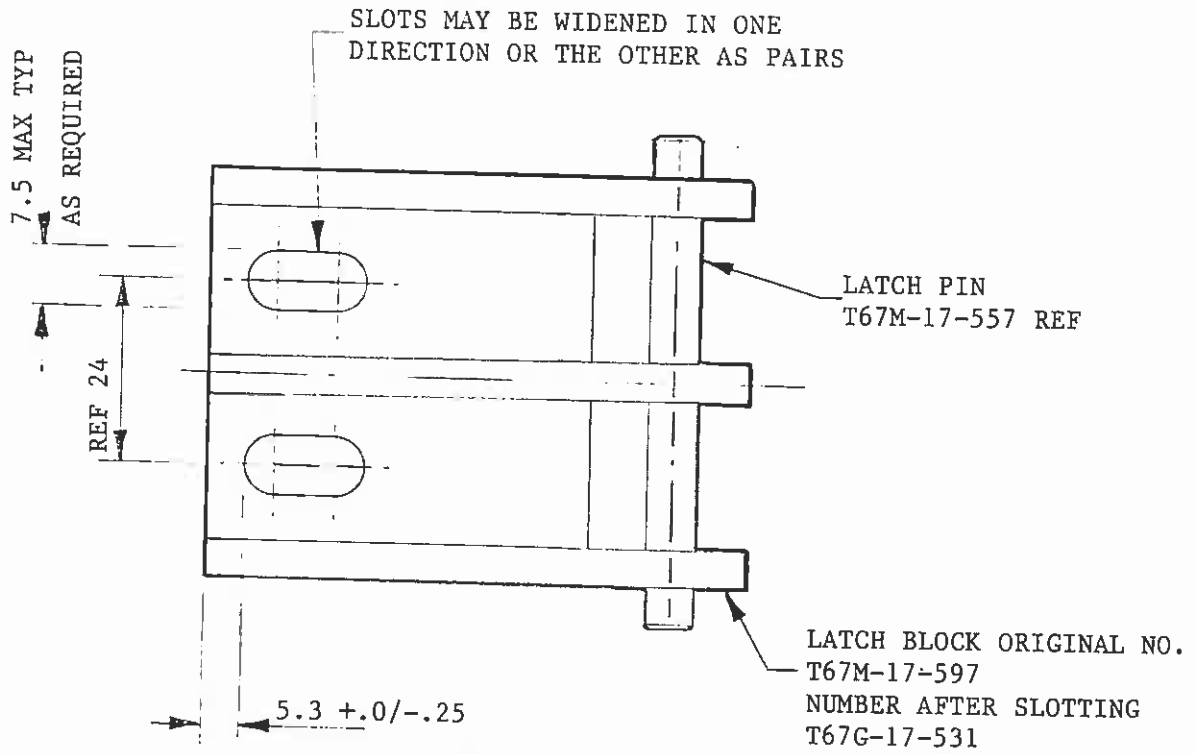

FIG 3

Approved:

Date:

20.6.96.

Page

5

of

5