

SERVICE BULLETIN

SB No. 56 Issue No. 2

TITLE
INSPECTION OF AIR INTAKE BOX BY-PASS FLAP HINGE.
CLASSIFICATION

This Service Bulletin has been classified as Highly Recommended

COMPLIANCE At next 50 hour check and as noted below

APPLICABILITY:

 Pre Mod M595 T67M and T67M-MkII.
 T67M200.

INTRODUCTION:

An incident has occurred whereby the rivets holding the hinge assembly to the air duct have loosened and the flap assembly has become detached.

ACTION:

1. Inspect the Air Duct Assembly for signs of loose rivets and loose hinge pin. Particular attention should also be paid to each piano hinge segment as cracks can develop in the area shown in Fig 1.
2. If three or more hinge segments are found to have cracked or loose hinge pins are found, the unit is not acceptable for continued service. Fit aircraft with new* or repaired unit and inspect i.a.w. Para 4.
3. If one or two hinge segments are found to have cracked the aircraft can continue to fly subject to further inspections at subsequent 50 hour checks, until paragraph 2 applies.
4. If no damage or cracks found, continue as applicable below:
 - 4.1 Ref T67M and T67M-MkII: If no cracks or damage are found repeat this inspection at every 50 hour check until para 2 or 3 applies.*
 - 4.2 Ref T67M200: If no cracks or damage are found, repeat this inspection at every subsequent 150 hr check until para 2 or 3 applies.

ISSUED BY:

Date 17.7.98.

 for and on behalf of SLINGSBY AVIATION LIMITED
 Kirkbymoorside York YO61 2Z England

 Tel 01751 432474
 Fax 01751 431173

Page 1 of 3

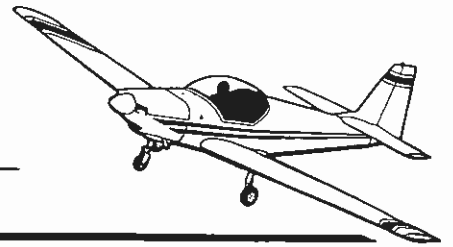

SERVICE BULLETIN

SB No.

56

Issue No.

2

TITLE

INSPECTION OF AIR INTAKE BOX BY-PASS FLAP HINGE

CONTINUED

5. Annotate in log book at each 50 hr check SB 56 complied with (150 hr ref paragraph 4.2).

For new or repaired units and assistance, contact SAL Product Support Department.

*For T67M and T67M-MkII incorporation of Mod M595 "Introduction of GRP Fuel Injector Air Intake Duct/Box Assy" removed the requirement of this Service Bulletin.

Approved:

A handwritten signature in black ink, appearing to be 'J. W. ...', written over a horizontal line.

Date:

17.7.98.

Page

2

of

3

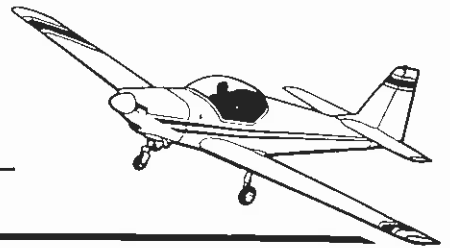

SERVICE BULLETIN

SB No.

56

Issue No.

2

TITLE

INSPECTION OF AIR INTAKE BOX BY-PASS FLAP HINGE.

CONTINUED

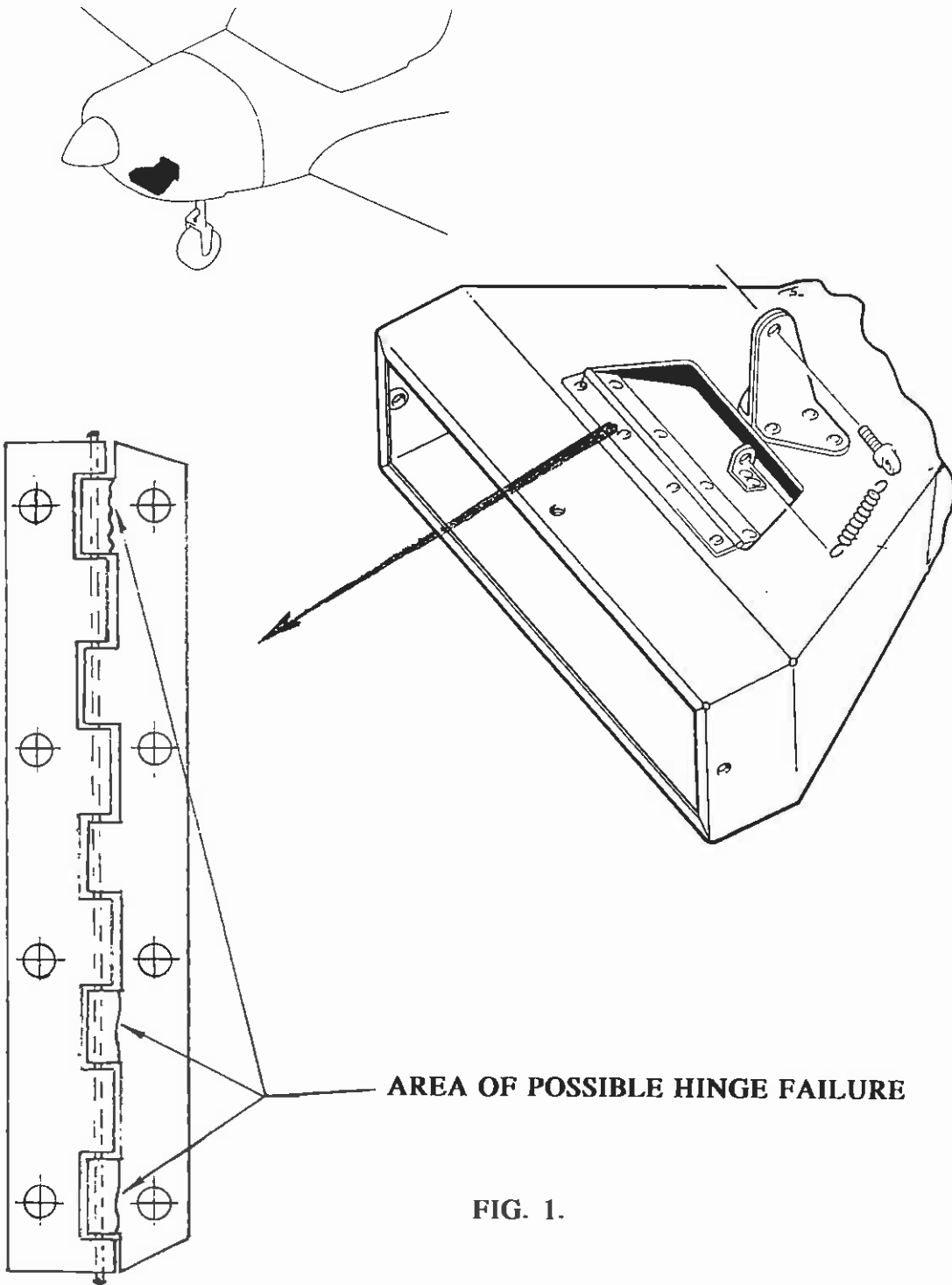
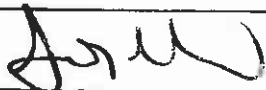

FIG. 1.

Approved:



Date:

17.7.98.

Page

3

of

3