

SERVICE BULLETIN

SB No.

99

Issue No.

2

TITLE
INSPECTION AND RECTIFICATION OF RUDDER PEDAL SLIDERS
CLASSIFICATION

This Service Bulletin has been classified by SAL as Highly Recommended

COMPLIANCE Within next 50 flying hours and at each subsequent 50 flying hours until Mod M704B invoked.

APPLICABILITY:

T67B, T67C Series, T67M (Not Works No. 1999), T67M-MkII, T67M200, T67M260 and T67M260-T3A.

INTRODUCTION:

Cases have been reported, during ground maintenance work, of the failure of a rudder pedal adjusting mechanism whereby the pedal position cannot be adjusted. Upon investigation it was found that the adjusting pin retaining bush had rotated causing the roll pin in the adjusting pin to disengage from the lifting mechanism fork.

Cases have also been reported of loose rivets in the upper slider to lower slider joint.

Additionally cherry type rivets may be used to replace the Tucker pop rivets attaching the pedal adjusting mechanism to the slider should the original have any play in them. This latter action is mainly a preventative action.

This Service Bulletin is written to address all three separate issues, and if necessary, to rectify both situations under one modification, Mod M704B.

ACTION

1. Remove each pedal/slider assembly and inspect for:
 - i) Correct operation of adjusting pin lifting mechanism, ie roll pin is engaged in fork, and for looseness of bush, ref Fig. 1.
 - ii) Check for any play in upper slider to lower slider attachment rivets, ref Fig. 2.
 - iii) Check for any play in adjusting mechanism attachment rivets, ref Fig. 3.

ISSUED BY:
Date

12.5.97

for and on behalf of

SLINGSBY AVIATION LIMITED
 Kirkbymoorside, York YO6 6EZ, England

 Tel. 01751 432474
 Fax 01751 431173

Page

1

of

6

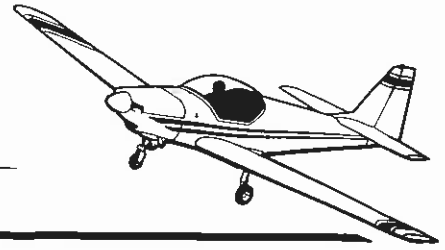
**SERVICE BULLETIN**

SB No.

99

Issue No.

2

TITLE

INSPECTION AND RECTIFICATION OF RUDDER PEDAL SLIDERS

CONTINUED

2. If either i), ii) or iii) are found to be unsatisfactory, then modify pedals in accordance with paragraph 4.
3. If i), ii) and iii) are found to be satisfactory, then annotate Log Book SB99 carried out. Repeat inspection at every 50 hours until Mod M704B carried out.
4. Modification Procedure:
 - 4.1 Remove pedal pad from slider mechanism.
 - 4.2 Addition of adjusting pin retaining bush anti turn rivet. Fig. 1.
 - 4.2.1 Ensure adjusting mechanism is aligned and is functioning correctly, with roll pin fully engaged in lifting mechanism fork.
 - 4.2.2 Position jig JT67G-45-227 onto upper slider, jig will only fit correctly one way.
 - 4.2.3 Drill 2.85mm dia (No.33 drill) 8mm deep hole. Fig. 1, Section A-A.
 - 4.2.4 Remove jig and csk 120° x 5mm dia.
 - 4.2.5 Using pop rivet gun fit pop rivet 126-24-031 (Tucker TLP/K319BS).
 - i) Ensure head is flush with surface of slider.
 - ii) Ensure adjusting pin and mechanism operate freely.
 - 4.3 Upper slider to lower slider attachment rivets.

Note:

- 1) On Pre Mod M277 aircraft, there are 4 attaching rivets in total. Replace rivets in accordance with the following sequence:

Drill out forward rivet one side and re-rivet, followed by diagonally opposite rivet etc.

Approved:

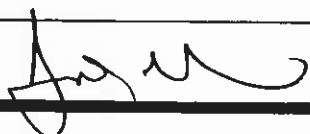

Date:

12.5.97

Page

2

of

6

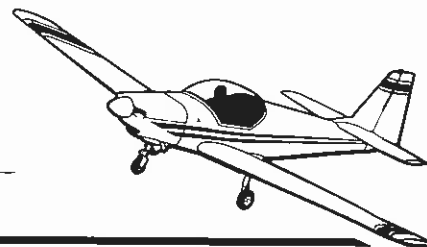
**SERVICE BULLETIN**

SB No.

99

Issue No.

2

TITLE

INSPECTION AND RECTIFICATION OF RUDDER PEDAL SLIDERS

CONTINUED

- 2) On Post Mod M277 aircraft there are 6 attaching rivets in total. Replace rivets in accordance with the following sequence:

Drill out forward rivet one side and re-rivet, followed by diagonally opposite aft rivet, re-rivet. Repeat with opposite forward and aft rivets. Finally centre rivet one side then opposite side centre.

- 4.3.1 Drill out existing rivets using 4mm dia drill. Ensure drill does not penetrate too far into slider assy.

- 4.3.2 Drill hole out to 4.5mm dia oversize and csk 120° x 8mm dia (1mm deep).

Prior to rivetting ensure upper slider is parallel (Ref 39mm dimension) to and in line with lower slider, and that the rivet head will be flush.

- 4.3.3 Rivet using suitable Cherry Max Rivet gun and rivet 126-24-051 (Cherry CR 3556P-5-3).

- 4.3.4 After rivetting check alignment and rivets for flushness. Rectify as necessary.

- 4.4 Adjusting mechanism attachment rivets, ref Fig. 3.

- 4.5 Identify pedal assy/slider mechanism with Mod M704B.

- 4.6 Replace pedal pads and replace pedal mechanism into aircraft. Check for correct and free operation, including positive location of the adjusting pin at each pedal position.

- 4.7 Annotate in Log Book Post Mod M704B accomplished.

For Mod Kit T67A-05-704B and drill jig, contact SAL Product Support Department.

Approved:

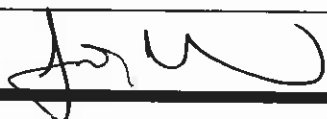

Date:

12.5.97

Page

3

of

6

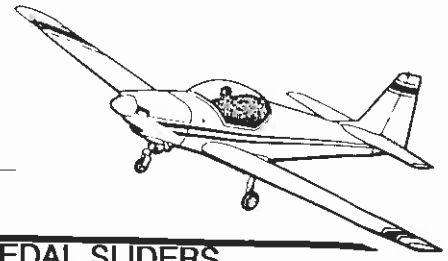

SERVICE BULLETIN

SB No. 99

Issue No. 2

TITLE **INSPECTION AND RECTIFICATION OF RUDDER PEDAL SLIDERS**

CONTINUED

ANTI TURN RIVET
TUCKER "POP"
126-24-031

$7.3 \begin{matrix} +.1 \\ \text{mm} \\ -0 \end{matrix}$

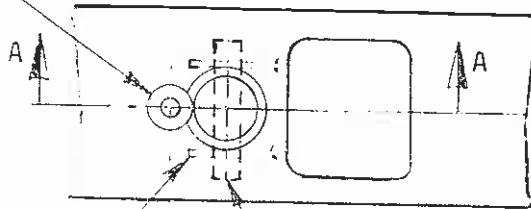

LIFTING MECHANISM FORK

ROLL PIN

PLAN VIEW

ADJUSTING PIN
RETAINING BUSH

ROLL PIN

LIFTING MECHANISM
FORK

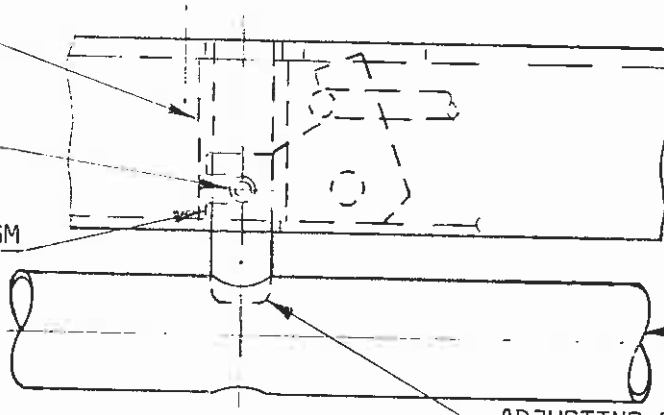

UPPER SLIDER

LOWER SLIDER

ADJUSTING PIN

FORWARD

SIDE VIEW

DRILL 2.85mm DIA

$7.3 \begin{matrix} +.1 \\ \text{mm} \\ -0 \end{matrix}$

120° CSK X 5 DIA

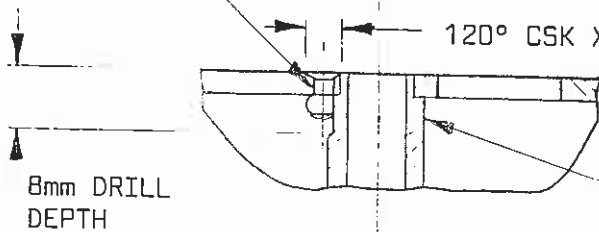

ADJUSTING PIN RETAINING
BUSH REF

SECTION A-A

FIG 1

ADJUSTING PIN POSITION IN PEDAL/SLIDER MECHANISM

Approved:

Date: 12.5.97

Page

4

of

6

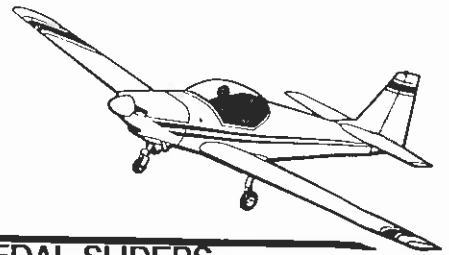

SERVICE BULLETIN

SB No. 99

Issue No. 2

TITLE INSPECTION AND RECTIFICATION OF RUDDER PEDAL SLIDERS

CONTINUED

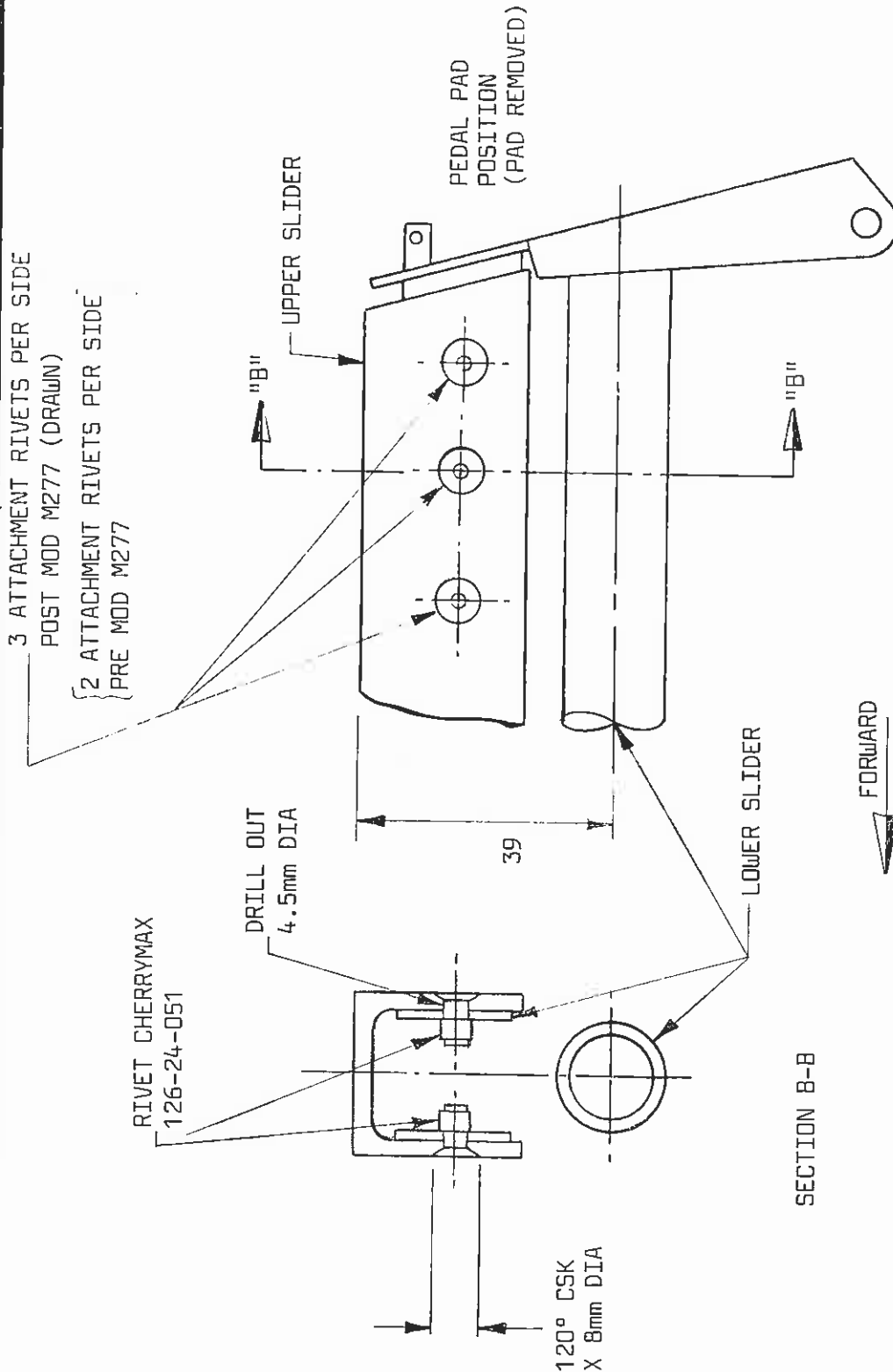

FIG 2
UPPER SLIDER TO LOWER SLIDER, PEDAL MECHANISM JOINT

Approved:

[Handwritten Signature]

Date: 12.5.97

Page 5 of 6

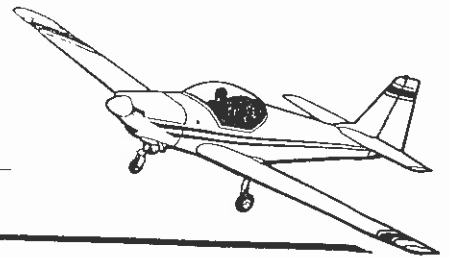

SERVICE BULLETIN

SB No.

99

Issue No.

2

TITLE

INSPECTION AND RECTIFICATION OF RUDDER PEDAL SLIDERS

CONTINUED

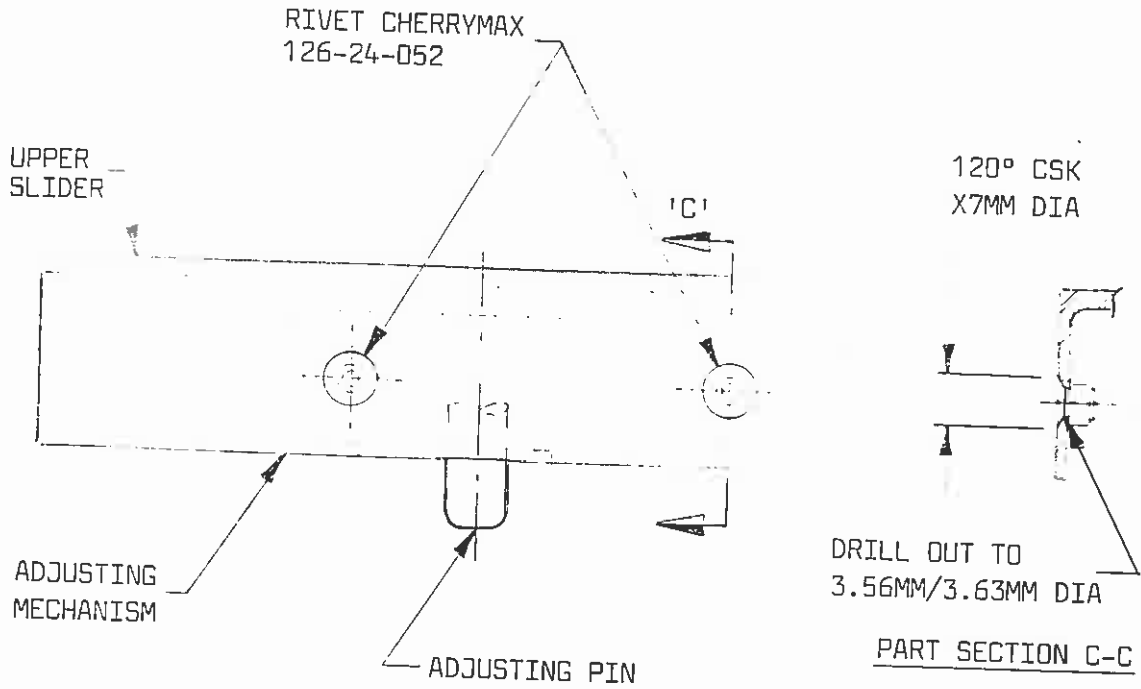

FIG 3
ADJUSTING MECHANISM ATTACHMENT TO SLIDER

Approved:

Date:

12.5.97

Page

6

of

6